

---

*JULY*

*TACOMA WATER*

2014

**FINANCIAL  
REPORT**





# Public Utility Board

DAVID NELSON

Chair

WOODROW JONES

Vice-Chair

BRYAN FLINT

Secretary

MARK PATTERSON

Member

MONIQUE TRUDNOWSKI

Member

WILLIAM A. GAINES  
Director of Utilities/CEO

LINDA MCCREA  
Superintendent

ANDREW CHERULLO  
Finance Director

DEPARTMENT OF PUBLIC UTILITIES

CITY OF TACOMA



CITY OF TACOMA, WASHINGTON  
DEPARTMENT OF PUBLIC UTILITIES, WATER DIVISION  
Doing Business As

# TACOMA WATER

## TABLE OF CONTENTS

*Note: These financial statements are interim, unaudited reports prepared primarily for the use of management. Not all transactions reported in these statements have been recorded on the full accrual basis of accounting or in accordance with generally accepted accounting principles.*

STATEMENTS OF NET POSITION .....	2 - 3
STATEMENTS OF REVENUES, EXPENSES AND CHANGES IN NET POSITION .....	4 - 5
SUMMARY OF REVENUES AND BILLINGS .....	6 - 7
SUMMARY OF WATER BILLED .....	8 - 9
SUPPLEMENTAL DATA .....	11 - 14

CITY OF TACOMA, WASHINGTON  
DEPARTMENT OF PUBLIC UTILITIES  
TACOMA WATER

STATEMENTS OF NET POSITION - JULY 31, 2014 AND JULY 31, 2013

<b>ASSETS</b>	<u>2014</u>	<u>2013</u>
<b>UTILITY PLANT</b>		
Water Plant in Service .....	\$854,409,356	\$825,831,116
Less Depreciation and Amortization .....	(176,555,942)	(165,005,351)
Total .....	<u>677,853,414</u>	<u>660,825,765</u>
Construction Work in Progress .....	172,049,198	102,028,623
Net Utility Plant .....	<u>849,902,612</u>	<u>762,854,388</u>
<b>NON-UTILITY PROPERTY</b> .....	492,963	547,480
<b>RESTRICTED ASSETS</b>		
Cash and Equity in Pooled Investments:		
2009 Construction Fund .....	-	1,027,642
2010 Construction Fund .....	188	20,323,825
2010 RWSS Construction Fund .....	424,784	7,131,181
2013 Construction Fund .....	39,259,315	50,722,062
Regional Water Supply System Operating Fund .....	1,957,050	16,013,826
Provision for Debt Payment .....	8,282,588	7,633,209
Customer Water Main Deposits .....	3,025,902	2,928,683
Water Supply Forum Fund.....	439,058	436,309
Special Bond Reserves .....	22,094,250	22,091,692
Water Customer Contribution Fund .....	152,918	125,652
Water Capital Reserves .....	22,690,357	19,331,892
Water System Development Charge .....	53,313,600	54,198,467
Notes & Contracts Receivables - SDC .....	-	462,128
Total Restricted Assets .....	<u>151,640,010</u>	<u>202,426,568</u>
<b>CURRENT ASSETS</b>		
Cash and Equity in Pooled Investments:		
Current Fund .....	39,630,519	32,473,964
Working Funds .....	1,000	1,500
Customers' Deposits .....	271,882	268,766
Receivables:		
Customers .....	4,763,936	4,438,717
Accrued Unbilled Revenues .....	4,494,710	4,026,679
Others .....	969,942	2,633,571
BABs Interest Subsidies .....	640,128	640,128
Provision for Uncollectible Accounts .....	(537,682)	(436,606)
Materials and Supplies .....	2,417,581	2,199,433
Prepayments .....	449,336	501,479
Total Current Assets .....	<u>53,101,352</u>	<u>46,747,631</u>
<b>TOTAL ASSETS</b> .....	<u>1,055,136,937</u>	<u>1,012,576,067</u>
<b>DEFERRED OUTFLOWS</b>		
Regulatory Assets - Public Fire Protection Fees .....	3,315,107	4,283,207
Regulatory Assets - Hyada Surcharges .....	868,079	966,368
Unamortized Losses on Refunding Bonds .....	1,682,021	1,908,027
Total Deferred Outflows .....	<u>5,865,207</u>	<u>7,157,602</u>
<b>TOTAL ASSETS AND DEFERRED OUTFLOWS</b> .....	<u><u>\$1,061,002,144</u></u>	<u><u>\$1,019,733,669</u></u>

*These statements should be read in conjunction with the Notes to Financial Statements contained in the 2013 Annual Report.*

<b>NET POSITION AND LIABILITIES</b>	<u>2014</u>	<u>2013</u>
<b>NET POSITION</b>		
Net Investment in Capital Assets .....	\$418,979,375	\$382,076,291
Restricted for:		
Water Capital Reserves .....	15,664,943	19,331,892
Water System Development Charge .....	18,200,281	19,564,335
Debt Service Funds .....	4,736,101	3,142,916
Unrestricted .....	<u>40,862,820</u>	<u>42,989,190</u>
TOTAL NET POSITION .....	498,443,520	467,104,624
<b>LONG-TERM DEBT</b>		
Revenue Bonds Outstanding:		
2005 Water Revenue Bonds Refunding .....	29,365,000	33,450,000
2009 Water Revenue Bonds .....	76,775,000	76,775,000
2010 Water Revenue Bonds Refunding .....	27,505,000	28,055,000
2010 Water Revenue Bonds .....	74,985,000	74,985,000
2013 Water Revenue Bonds Refunding .....	74,355,000	75,335,000
2010 RWSS Revenue Bonds, Series A .....	44,245,000	44,245,000
2010 RWSS Revenue Bonds, Series B .....	3,070,000	3,335,000
2013 RWSS Refunding Bonds .....	<u>62,765,000</u>	<u>63,835,000</u>
Total Outstanding Revenue Bonds .....	393,065,000	400,015,000
Plus: Unamortized Bond Premium .....	<u>14,790,719</u>	<u>16,265,892</u>
Net Outstanding Revenue Bonds .....	407,855,719	416,280,892
PWTF Pre-Construction Loans .....	5,197,601	5,728,363
PWTF Construction Loans .....	22,903,947	25,069,956
State Drinking Water Loan .....	<u>40,589,417</u>	<u>17,789,716</u>
Total Long-Term Debt .....	476,546,684	464,868,927
<b>CURRENT LIABILITIES</b>		
Salaries and Wages Payable .....	1,060,186	965,703
Purchases and Contracts Payable .....	4,211,888	6,321,716
Interest Expense Accrued .....	3,546,487	4,490,295
Taxes Accrued .....	1,476,467	1,326,307
Customers' and Contractors' Deposits .....	339,897	289,652
Current Portion of Long-Term Debt .....	11,009,843	10,237,522
Other Current Liabilities .....	2,375,000	2,247,174
Current Accrued Compensated Absences .....	<u>249,552</u>	<u>235,807</u>
Total Current Liabilities .....	24,269,320	26,114,176
<b>LONG-TERM LIABILITIES</b>		
Muckleshoot Agreements .....	7,320,231	7,515,530
Customer Advances for Construction .....	4,160,610	4,494,931
Unearned Revenue .....	8,852,373	8,976,454
Other Deferred Credits .....	3,587,992	2,961,322
Long Term Accrued Compensated Absences .....	<u>2,245,968</u>	<u>2,122,259</u>
Total Long-Term Liabilities .....	<u>26,167,174</u>	<u>26,070,496</u>
TOTAL LIABILITIES .....	<u>526,983,178</u>	<u>517,053,599</u>
<b>DEFERRED INFLOWS</b>		
Rate Stabilization .....	<u>35,575,446</u>	<u>35,575,446</u>
TOTAL NET POSITION, LIABILITIES AND DEFERRED INFLOWS .	<u><u>\$1,061,002,144</u></u>	<u><u>\$1,019,733,669</u></u>

CITY OF TACOMA, WASHINGTON  
DEPARTMENT OF PUBLIC UTILITIES  
TACOMA WATER

STATEMENTS OF REVENUES, EXPENSES AND CHANGES IN NET POSITION  
JULY 31, 2014 AND JULY 31, 2013

	<u>July 2014</u>	<u>July 2013</u>
<b>OPERATING REVENUES</b>		
Sales of Water .....	\$6,672,414	\$5,930,372
Other Operating Revenues .....	715,998	699,721
Contract Resource Obligation Revenue .....	260,122	353,704
Total Operating Revenues .....	<u>7,648,534</u>	<u>6,983,797</u>
<b>OPERATING EXPENSES</b>		
Production Expense		
Source of Supply .....	505,113	545,279
Water Treatment .....	355,144	398,611
Total Production Expense .....	<u>860,257</u>	<u>943,890</u>
Power Pumping Expense .....	38,758	41,593
Transmission and Storage Expense .....	215,217	130,268
Distribution Expense .....	982,227	853,502
Customer Accounting and Consumer Service ...	362,591	330,355
Taxes .....	308,632	285,296
Depreciation .....	1,395,130	1,333,096
Administrative and General .....	638,679	638,618
Total Operating Expenses .....	<u>4,801,491</u>	<u>4,556,618</u>
<b>OPERATING INCOME (LOSS) .....</b>	<b>2,847,043</b>	<b>2,427,179</b>
<b>NON-OPERATING REVENUES (EXPENSES)</b>		
Interest Income .....	135,119	129,836
Miscellaneous .....	556,863	(8,943)
Interest on Long-Term Debt .....	(1,378,724)	(1,264,483)
Interest on Long-Term Debt BABs Sub .....	(320,064)	(320,064)
Amortization Of Debt Premium .....	92,947	119,707
Interest Charged to Construction.....	631,821	78,356
Total Non-Operating Revenues (Expenses) .....	<u>(282,038)</u>	<u>(1,265,591)</u>
Net Income (Loss) Before Capital Contributions and Transfers .....	2,565,005	1,161,588
Capital Contributions		
Cash .....	139,191	359,930
Donated Fixed Assets .....	263,898	-
Federal BAB Subsidies .....	320,064	320,064
Transfers Out		
City Gross Earnings Tax .....	<u>(585,137)</u>	<u>(559,313)</u>
<b>CHANGE IN NET POSITION .....</b>	<b><u>\$2,703,021</u></b>	<b><u>\$1,282,269</u></b>
TOTAL NET POSITION - JANUARY 1 .....		
TOTAL NET POSITION - JULY 31 .....		



YEAR TO DATE		2014 OVER (UNDER) 2013	PERCENT CHANGE
July 31 2014	July 31 2013		
\$ 37,622,494	\$ 33,853,458	\$3,769,036	11.1%
5,361,557	5,099,903	261,654	5.1%
11,349,601	18,947,800	(7,598,199)	-40.1%
54,333,652	57,901,161	(3,567,509)	-6.2%
3,417,177	3,010,422	406,755	13.5%
2,289,061	2,066,982	222,079	10.7%
5,706,238	5,077,404	628,834	12.4%
315,834	270,049	45,785	17.0%
1,644,229	1,635,551	8,678	0.5%
6,488,417	6,320,529	167,888	2.7%
2,363,057	2,266,349	96,708	4.3%
1,996,898	1,946,349	50,549	2.6%
9,750,333	9,331,670	418,663	4.5%
4,176,820	4,380,914	(204,094)	-4.7%
32,441,826	31,228,815	1,213,011	3.9%
21,891,826	26,672,346	(4,780,520)	-17.9%
965,762	95,759	870,003	908.5%
282,564	(1,241,018)	1,523,582	-122.8%
(9,779,551)	(9,497,475)	(282,076)	3.0%
(2,102,178)	(2,073,374)	(28,804)	1.4%
650,632	1,069,779	(419,147)	-39.2%
4,009,955	886,843	3,123,112	352.2%
(5,972,816)	(10,759,486)	4,786,670	-44.5%
15,919,010	15,912,860	6,150	0.0%
2,791,489	2,271,200	520,289	22.9%
741,194	65,082	676,112	1038.9%
2,102,180	2,073,374	28,806	1.4%
(3,399,326)	(3,076,028)	(323,298)	10.5%
18,154,547	17,246,488	908,059	5.3%
480,288,973	449,858,136	30,430,837	6.8%
\$498,443,520	\$467,104,624	\$31,338,896	6.7%

*These statements should be read in conjunction with the Management Discussion and Analysis in the June 2014 Financial Report.*

CITY OF TACOMA, WASHINGTON  
DEPARTMENT OF PUBLIC UTILITIES  
TACOMA WATER

SUMMARY OF REVENUES AND BILLINGS  
JULY 31, 2014 AND JULY 31, 2013

	JULY 2014	JULY 2013
<b>SALES OF WATER</b>		
Residential and Domestic .....	\$4,092,195	\$3,699,591
Commercial and Industrial .....	1,264,275	1,071,267
Special Rate .....	478,579	435,414
Municipal .....	36,985	29,773
Other Public Buildings and Grounds .....	291,403	255,385
Sales to Other Utilities .....	508,977	438,942
Total .....	\$6,672,414	\$5,930,372

**BILLINGS (NUMBER OF MONTHS BILLED)**

Residential and Domestic .....	86,585	85,992
Commercial and Industrial .....	6,134	6,069
Municipal .....	260	193
Other Public Buildings and Grounds .....	441	420
Sales to Other Utilities .....	20	20
Total .....	93,440	92,694

YEAR TO DATE		2014 OVER (UNDER) 2013	PERCENT CHANGE
JULY 2014	JULY 2013		
\$23,843,975	\$21,747,949	\$2,096,026	9.6%
7,128,323	6,203,990	924,333	14.9%
3,330,471	2,925,038	405,433	13.9%
233,638	246,382	(12,744)	-5.2%
1,170,949	1,062,384	108,565	10.2%
<u>1,915,138</u>	<u>1,667,715</u>	<u>247,423</u>	14.8%
<u>\$37,622,494</u>	<u>\$33,853,458</u>	<u>\$3,769,036</u>	11.1%
642,580	631,228	11,352	1.8%
40,744	39,974	770	1.9%
1,540	1,430	110	7.7%
2,917	2,809	108	3.8%
<u>134</u>	<u>129</u>	<u>5</u>	3.9%
<u>687,915</u>	<u>675,570</u>	<u>12,345</u>	1.8%

CITY OF TACOMA, WASHINGTON  
DEPARTMENT OF PUBLIC UTILITIES  
TACOMA WATER

SUMMARY OF WATER BILLED  
JULY 31, 2014 AND JULY 31, 2013

	MILLION GALLONS, TOTAL			
	JULY	JULY	YEAR TO DATE	
	2014	2013	JULY 2014	JULY 2013
WATER BILLED				
Residential and Domestic .....	818.88	773.66	4,031.80	3,998.06
Commercial and Industrial .....	269.88	253.51	1,436.99	1,323.63
Special Rate .....	500.04	502.08	3,489.88	3,380.09
Municipal .....	4.55	4.43	32.25	45.82
Other Public Bldgs and Grounds .....	71.64	66.28	231.01	220.53
Sales to Other Utilities .....	192.84	167.07	884.22	577.46
	1,857.83	1,767.03	10,106.15	9,545.59

NOTE: For conversion purposes, there are approximately 748 gallons in every 100 cubic feet of water.

MILLION GALLONS, AVERAGE DAILY

<u>JULY 2014</u>	<u>JULY 2013</u>
26.42	24.96
8.71	8.18
16.13	16.20
0.15	0.14
2.31	2.14
<u>6.22</u>	<u>5.39</u>
<u><u>59.94</u></u>	<u><u>57.01</u></u>

*This page has been left blank intentionally.*

# Supplemental Data

**WATER SALES**  
Year to Date - July 2014 & 2013

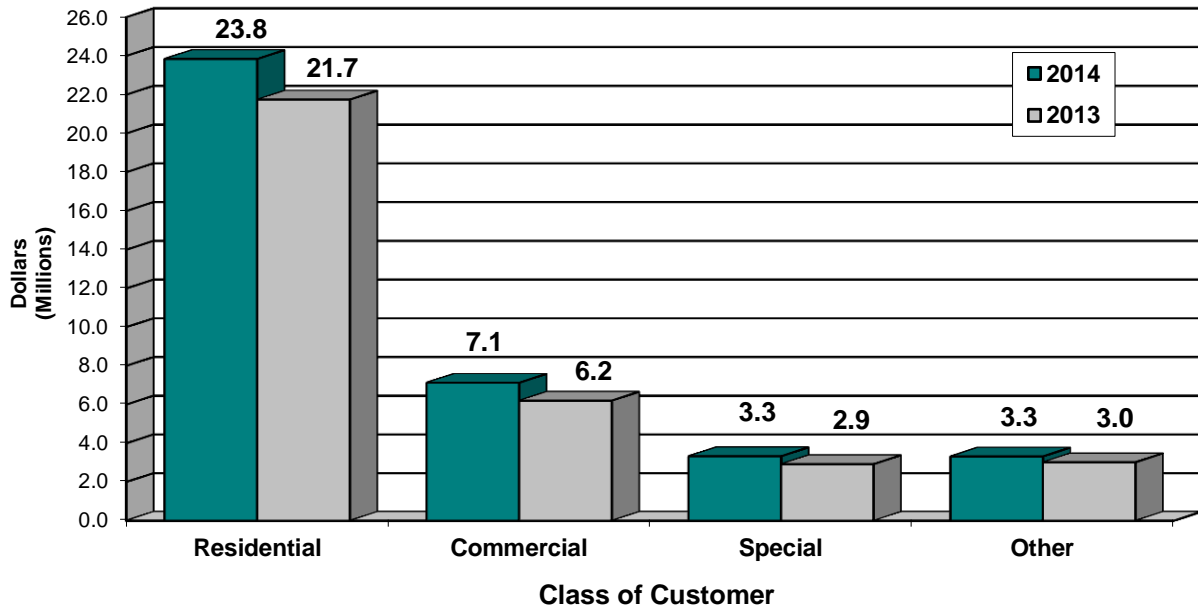

**WATER CONSUMPTION**  
Year to Date - July 2014 & 2013

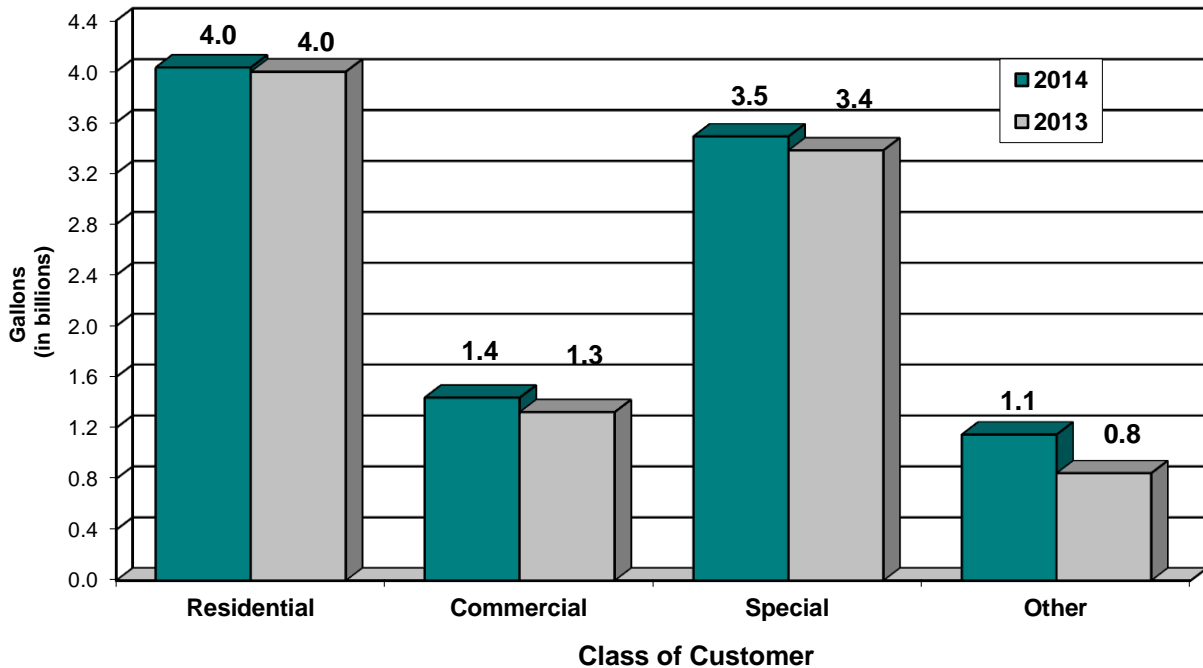



**WATER SALES**  
Year to Date - July 2014  
(\$37,622,494)

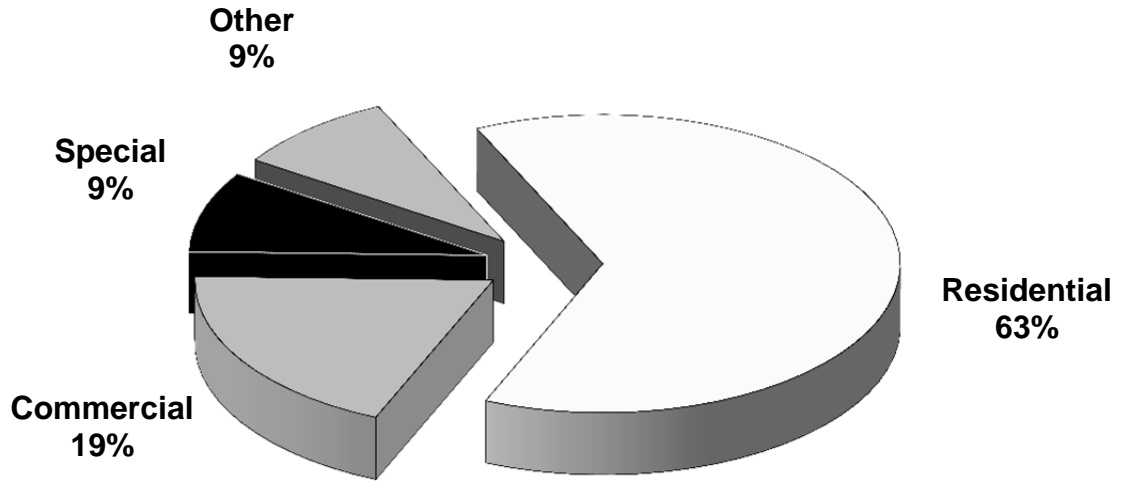

**WATER SALES**  
Year to Date - July 2013  
(\$33,853,458)

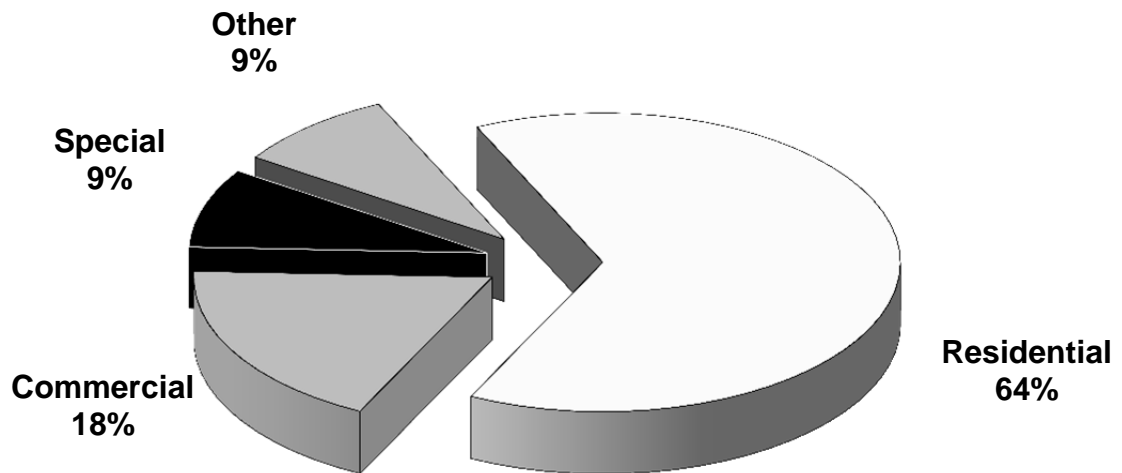

**TOTAL OPERATING EXPENSES**  
Year to Date - July 2014  
(\$32,441,826)

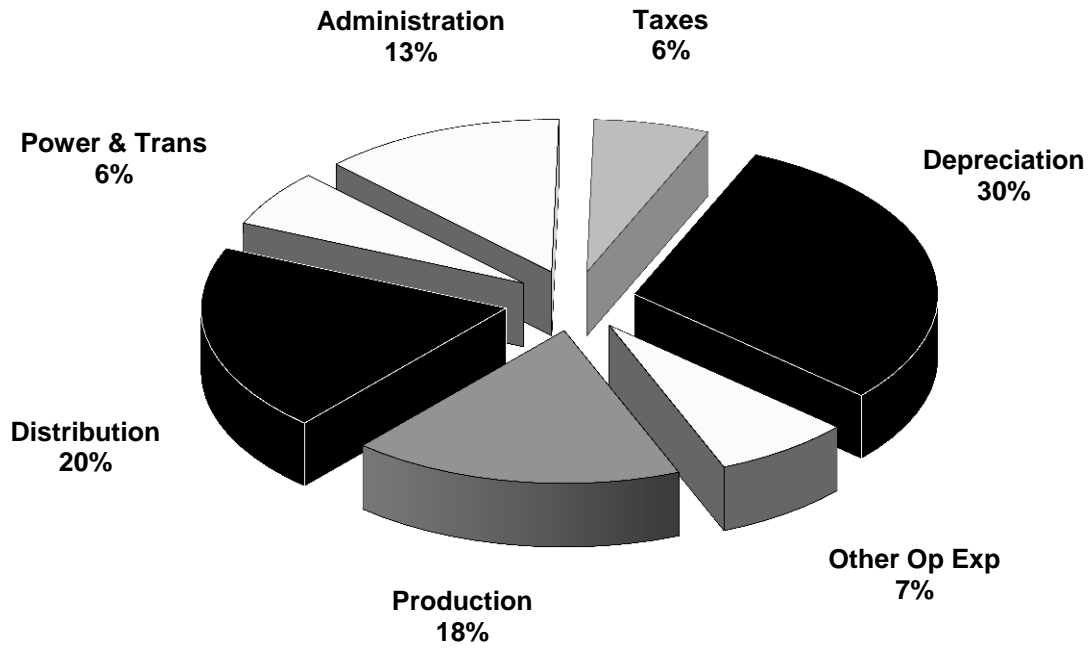

**TOTAL OPERATING EXPENSES**  
Year to Date - July 2013  
(\$31,228,815)

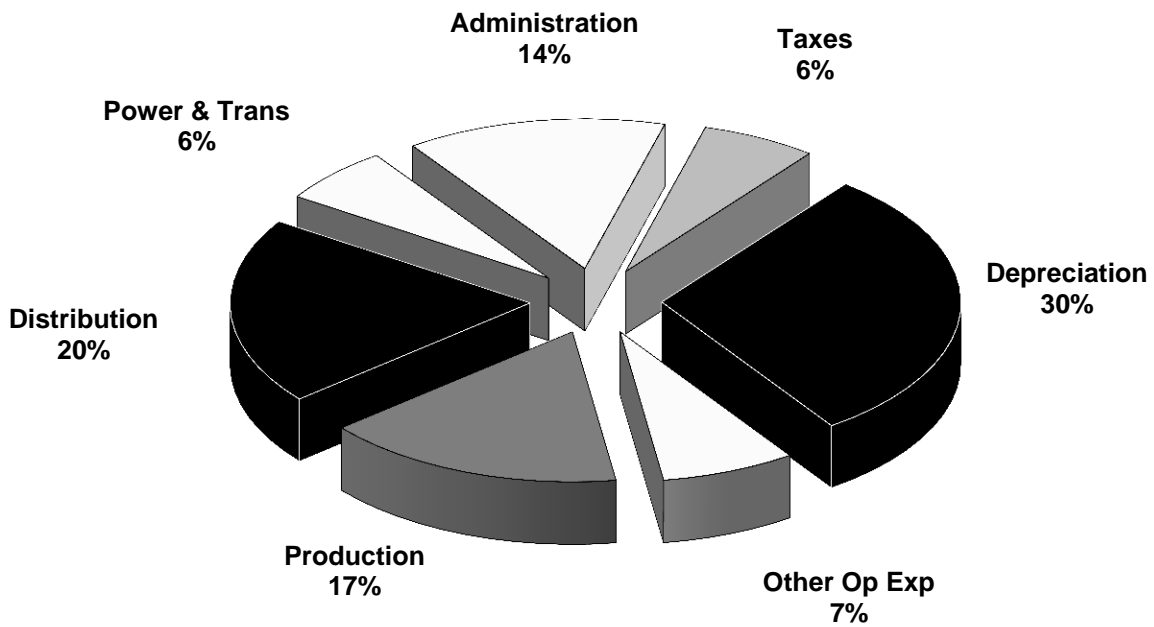



The City of Tacoma does not discriminate on the basis of disability in any of its programs, activities, or services. To request this information in an alternative format or to request a reasonable accommodation, please contact the City Clerk's Office at (253) 591-5505. TTY or speech to speech users please dial 711 to connect to Washington Relay Services.